

Vacuum Glass Lifter VB8 RCMBM

The VB8 is vacuum lifter for construction site use, with battery operating system and dual vacuum circuit.

The VB8 is a below-the-hook lifting accessory suitable for lifting and handling of glass units weighing up to 600 kg. The VB8 RCMBM features manual tilt and manual 360 degree rotation.

Its compact and flat design permit that VB8 could work also behind scaffoldings.

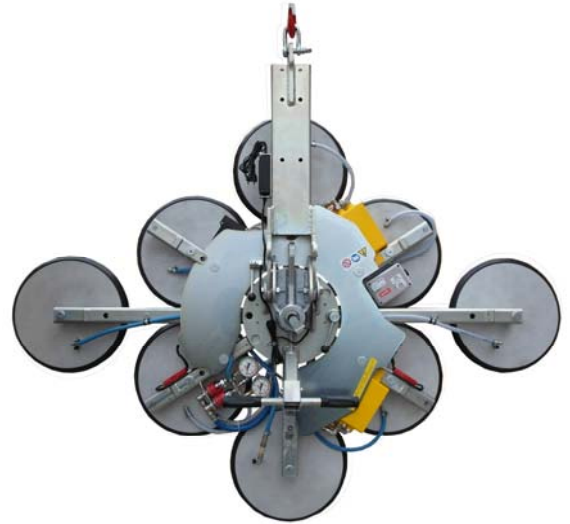

Technical specification

Application	glass panels
Lifting capacity	max 800 kg
Suction pads	number 8 round pad, diameter 310mm lipped pads with safety ring
Pad spread	mm 1420x970 in standard configuration
Load movement	continuous 360 degree rotation , with possibility of automatic locking at each 90° 90 degree tilt, with possibility of automatic locking in upright and flat position
Operating system	DC vacuum pump powered from on-board batteries high capacity re-chargeable batteries battery status indicator economizer for reduction of the energy consumption
Vacuum system	2 independent vacuum circuits, each vacuum circuit with vacuum reserve and non return valve
Weight of lifter	Kg 115
Structural depth	mm 250
Control	Manual slider valve for suction / release on the device release of the load by unique dual action command Remote control as optional
Standard features	Audible and visual low vacuum warning devices Vacuum gauge for each vacuum circuit Battery charger 240 Volt Vacuum filter Multi position hook connection Lowered suspension for installing of transom window

- Lifting capacity max 800 kg
 - No.8 suction pads Ø 310 mm
 - Battery operating system
 - Manual continues 360° rotation
 - Manual 90° tilt
 - Low vacuum warning device
 - Compact and slim frame
- ✓ Dual vacuum circuit built to EN13155 standard

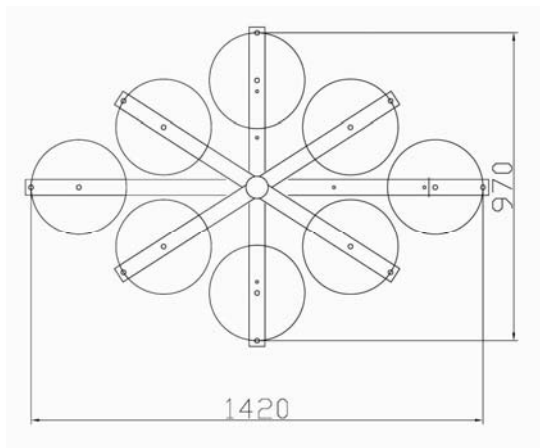

Available Optional

Extension pad arms to move the suction pads to larger position

Additional pad arms with suction pad to increase lifting capacity and pad spread

Controlled tilting device

Radio remote control

Inclination pole

Optional in-line pads position + vacuum pad shutoffs

ACOUSTIC AND VISUAL ALARM alert the operator on possible dangerous situation

LOW VACUUM LOSS VACUUM PADS WITH SPECIAL SEALING LIPS for extra security suction pads with spring system in order to improve suction and placement of the glass and to best compensate the flexion of glass sheets

VACUUM TANK

LONG LIFE HIGH CAPACITY BATTERIES

BATTERY INDICATOR that averts the operator when the batteries have no charge

VACUUM GAUGE with coloured scale for monitoring the vacuum level in each vacuum circuit

DOUBLE ACTION OFF command

RADIO REMOTE CONTROL on request

ROTATION BLOCK available on all models with manual rotation

TILTING BLOCK at 0° and 90° available on all models with manual tilt

SUSPENSIONS for obtaining various angles

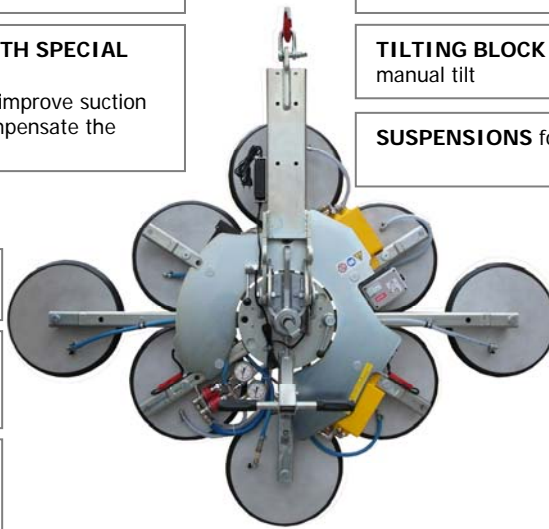

✓ **dual vacuum circuit for construction site**

LOWERED SUSPENSION for installation of transom windows offers a coupling point in the center of the lifter, allowing a reduced distance of the hook.



Available optional

Additional pad arms

increase lifting capacity and pad spread and permit to handling better large format panels

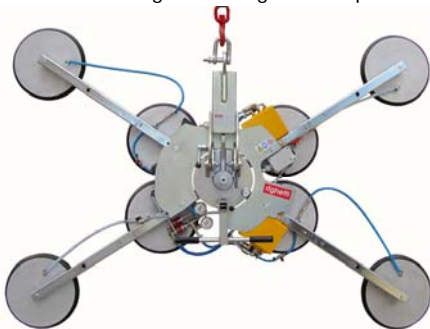

In line pads position + vacuum pad shutoffs

Particular lockable interval of rotation that permits to straighten the suction pads to in-line position. This option included possibility of exclusion of some suction pads.

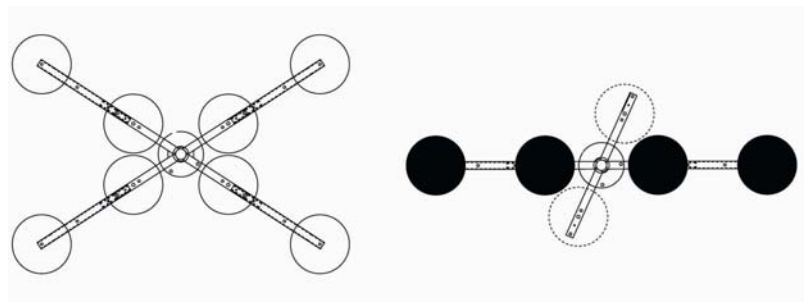

Controlled tilting device

is a mechanism of regulation that permits to control with high precision the manual tilting and takes easy the inclination of the load.



The Inclination Pole

is a highly useful instrument in adjusting the degrees of inclination during tilting and aids in obtaining exactly 90° in order to facilitate the installation of glass. The inclination pole is removable.



This lifter is available also in the following versions:

- with electric rotation and/or tilt
- with 220V/380V electric operating system
- with larger suction pads